

SECTION 15

SINGLE STAGE PUMPS

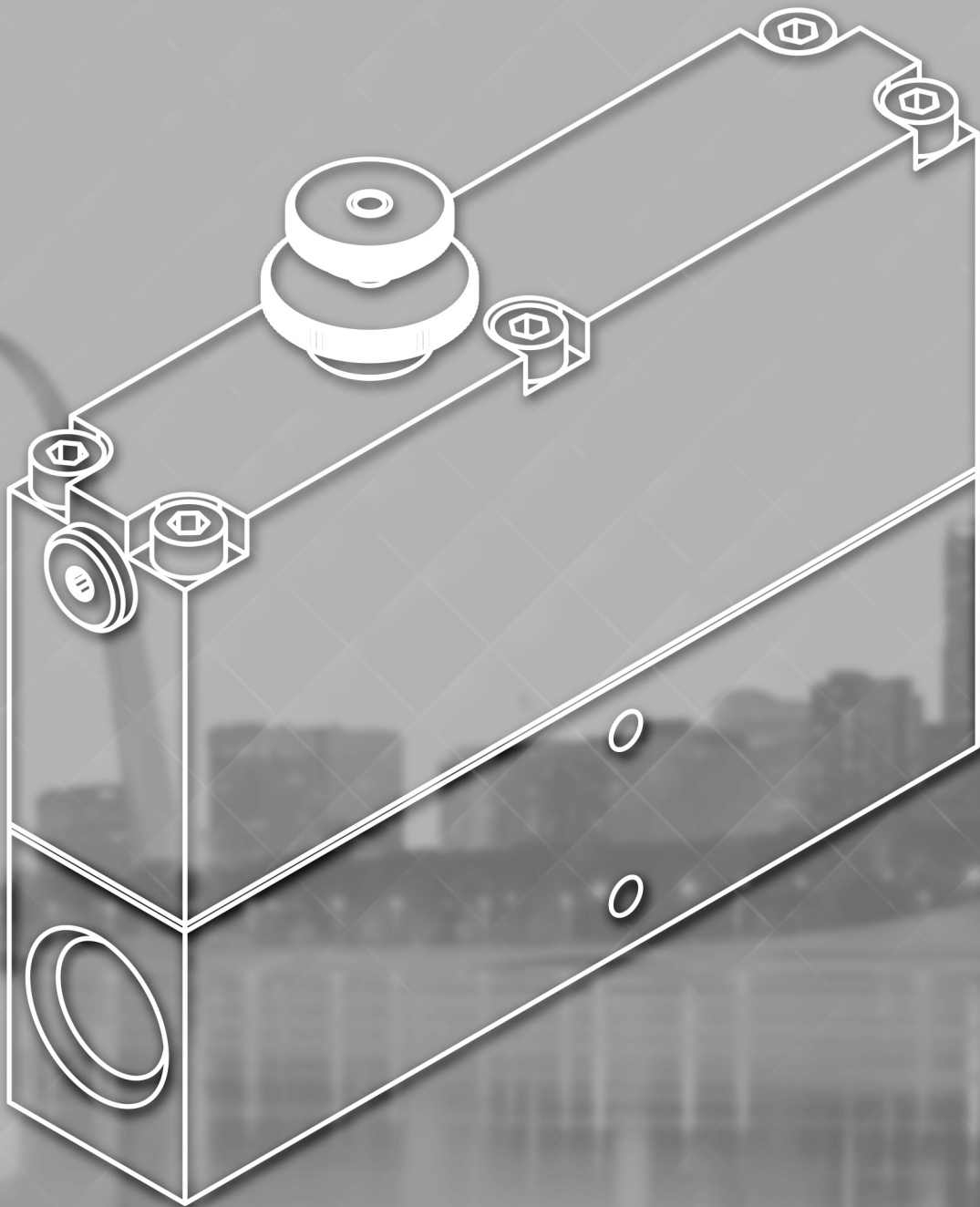

EDCO USA[®]

SINGLE-STAGE PUMPS

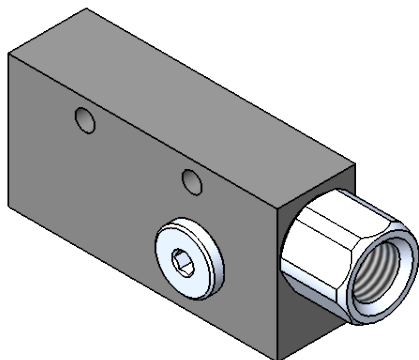

EV SERIES

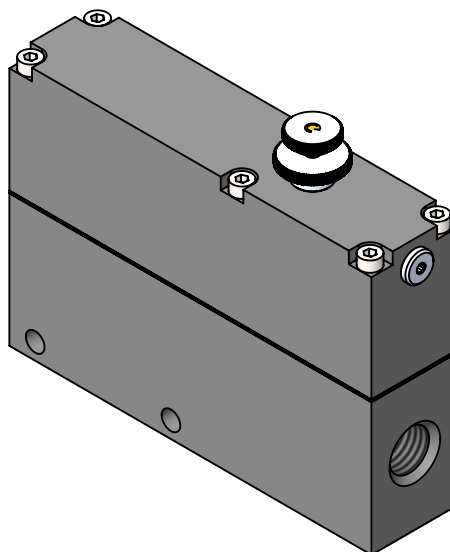

V SERIES

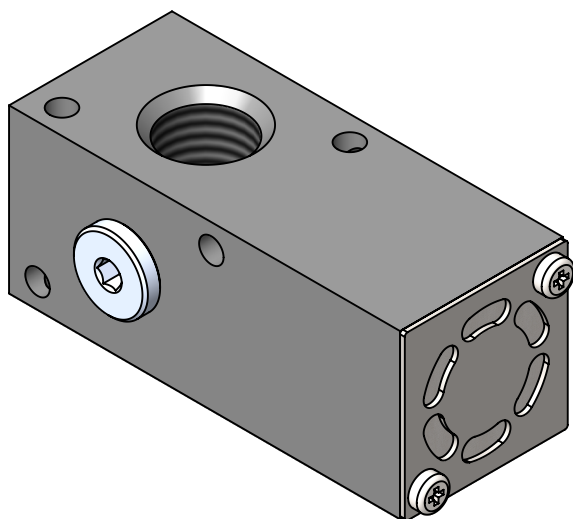

SM SERIES

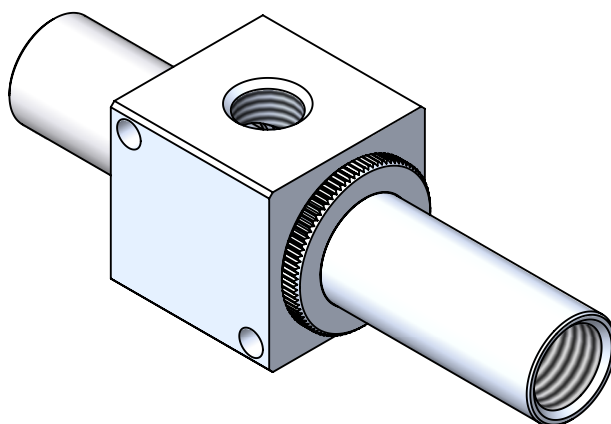

VARIABLE DISPLACEMENT PUMPS

EV Series	15:3 - 15:7
V Series	15:8 - 15:14
SM Series	15:15 - 15:16
Variable Displace Pumps	15:17 - 15:18

SINGLE-STAGE PUMPS

EV SERIES PUMPS

EV mono-stage vacuum generators provide a compact, lightweight, low-cost vacuum source for pick & place and material handling applications. The simple two-piece design allows ingested debris to exit the exhaust port. The optional "ST" straight-through exhaust silencer is a no-clog design that will pass ingested debris to atmosphere.

Construction is aluminum with anodized pump body and brass ejectors.

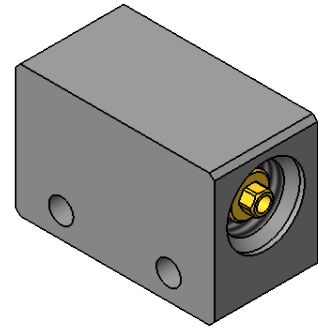

SILENCER	
EV05HS-	
	(Blank) = None
	ST = STA14M

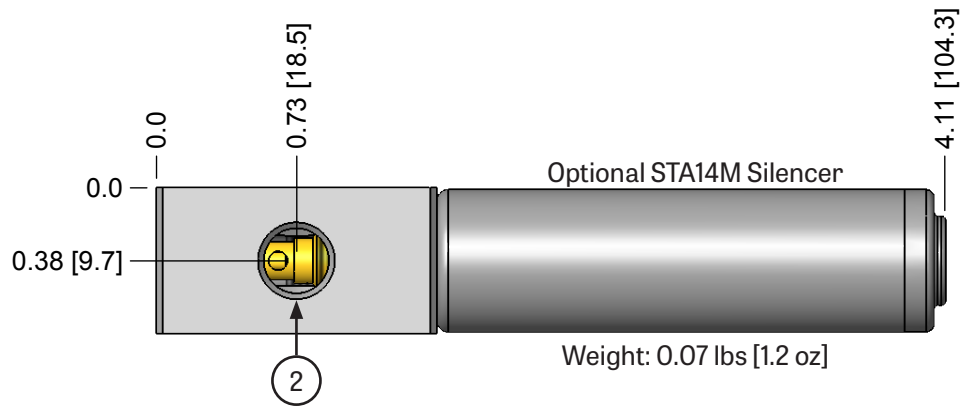
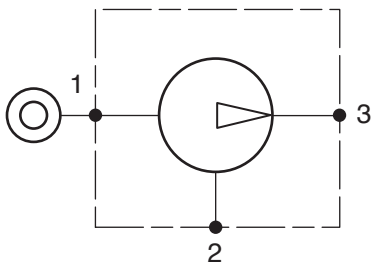
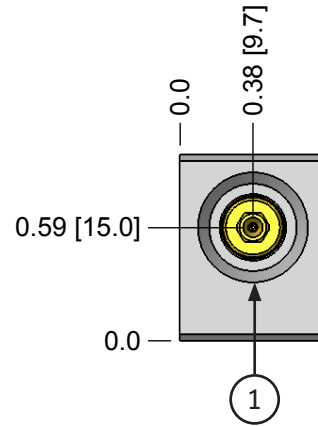
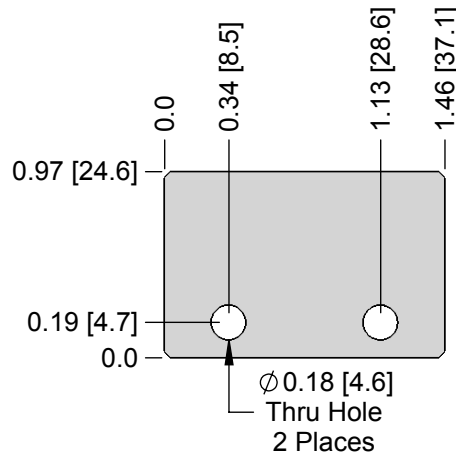
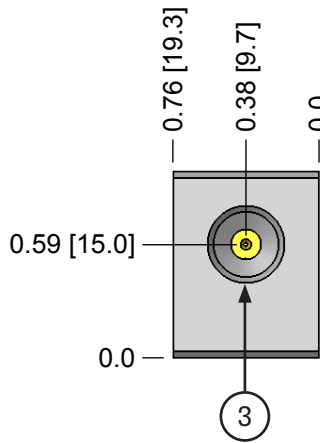

CODE	FUNCTION	PORT
1	Air Supply	G 1/8 NPSF
2	Vacuum	G 1/8 NPSF
3	Exhaust	G 1/4

SINGLE-STAGE PUMPS

EV SERIES PUMPS

EV mono-stage vacuum generators provide a compact, lightweight, low-cost vacuum source for pick & place and material handling applications. The simple two-piece design allows ingested debris to exit the exhaust port. The optional "ST" straight-through exhaust silencer is a no-clog design that will pass ingested debris to atmosphere.

A G1/8 NPSF auxiliary vacuum port is included so a gauge or vacuum switch can be easily added to complete a system. Construction is aluminum with anodized pump body and electroless nickel-plated primary nozzle.

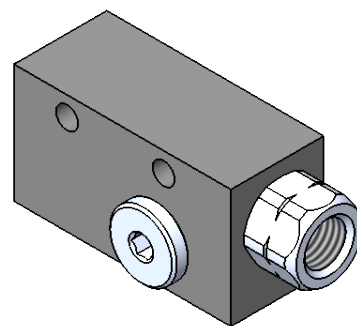

SILENCER	
EV10HS-	(Blank) = None
	ST = STA18M

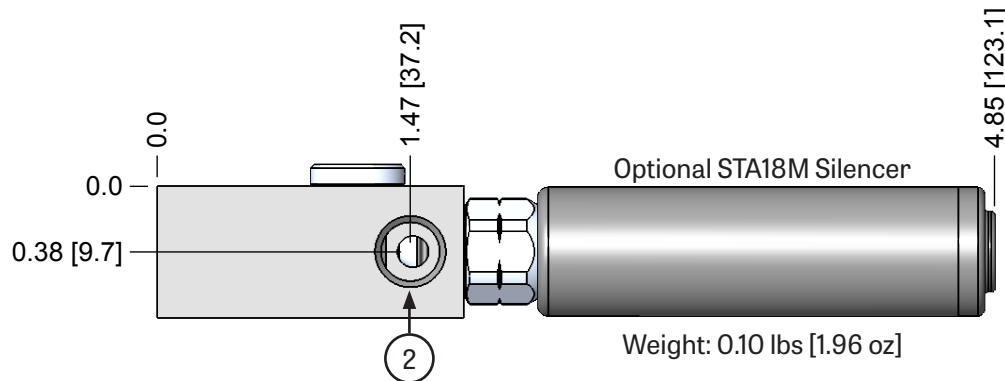
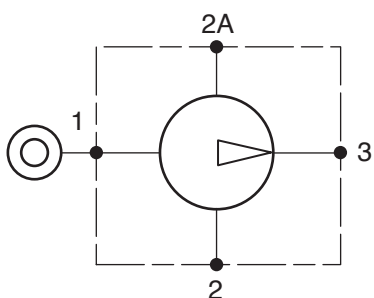
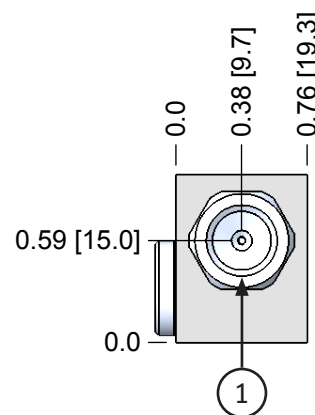
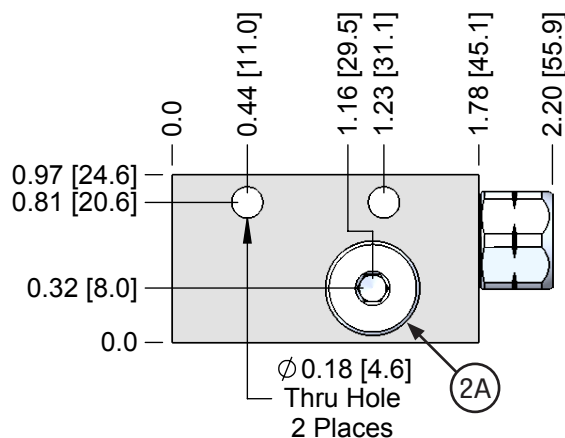
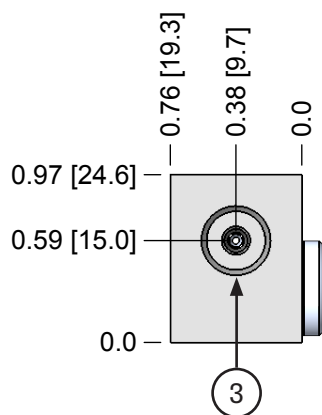

CODE	FUNCTION	PORT
1	Air Supply	G 1/8 NPSF
2	Vacuum	G 1/8 NPSF
2A	Vacuum - Alternate	G 1/8 NPSF
3	Exhaust	G 1/4

SINGLE-STAGE PUMPS

EV SERIES PUMPS

EV mono-stage vacuum generators provide a compact, lightweight, low-cost vacuum source for pick & place and material handling applications. The simple two-piece design allows ingested debris to exit the exhaust port. The optional "ST" straight-through exhaust silencer is a no-clog design that will pass ingested debris to atmosphere.

A G1/8 NPSF auxiliary vacuum port is included so a gauge or vacuum switch can be easily added to complete a system. Construction is aluminum with anodized pump body and electroless nickel-plated primary nozzle.

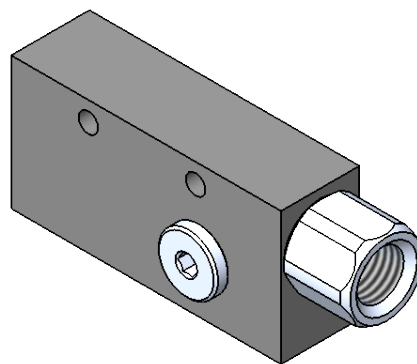

	THREADS	SILENCER
EV15HS-	(Blank) = None	(Blank) = None
	G = G Threads	ST = STA14M

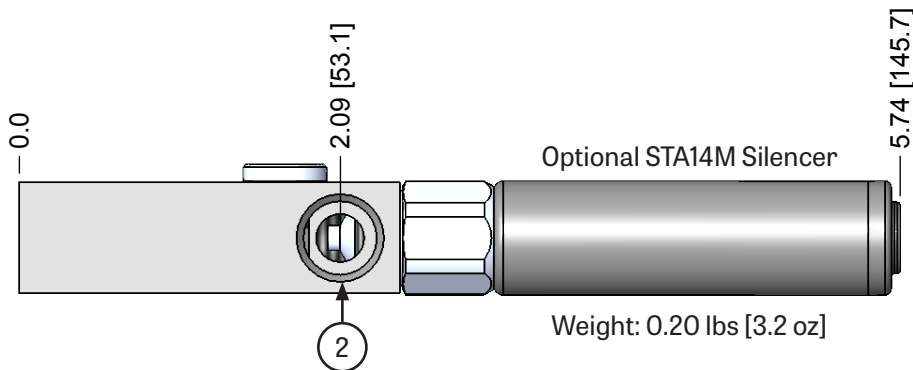
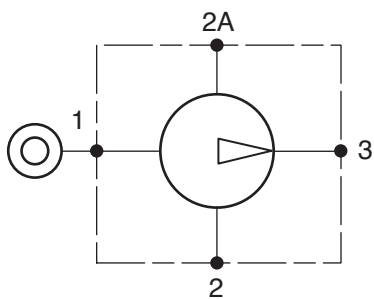
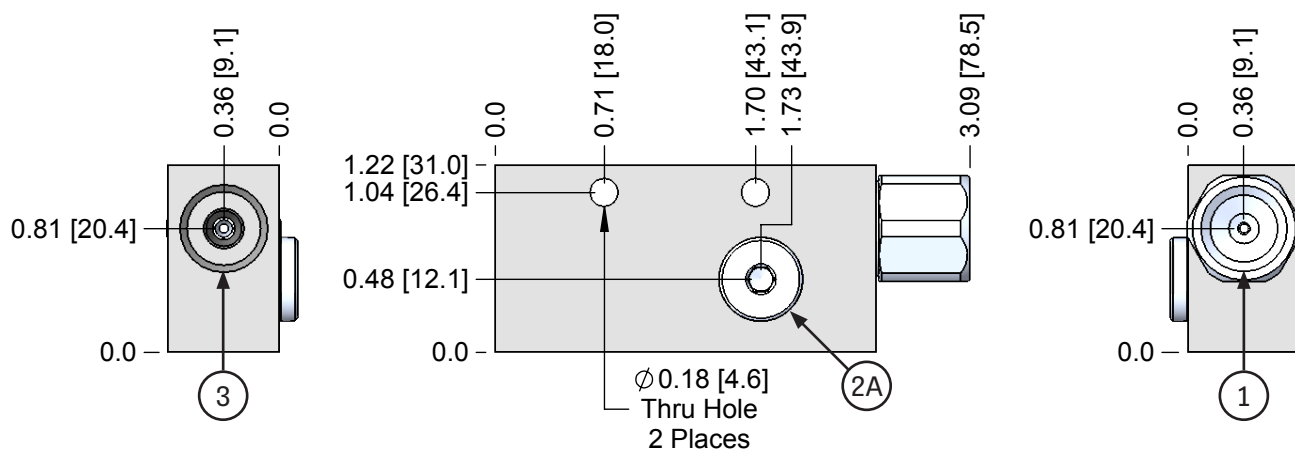

CODE	FUNCTION	NPT	G
1	Air Supply	1/4 NPTF	G 1/4
2	Vacuum	1/4 NPTF	G 1/4
2A	Vacuum - Alternate	G 1/8 NPSF	G 1/8 NPSF
3	Exhaust	1/4 NPTF	G 1/4

SINGLE-STAGE PUMPS

EV SERIES PUMPS

EV mono-stage vacuum generators provide a compact, lightweight, low-cost vacuum source for pick & place and material handling applications. The simple two-piece design allows ingested debris to exit the exhaust port. The optional "ST" straight-through exhaust silencer is a no-clog design that will pass ingested debris to atmosphere.

A G1/8 NPSF auxiliary vacuum port is included so a gauge or vacuum switch can be easily added to complete a system. Construction is aluminum with anodized pump body and electroless-nickel plated primary nozzle.

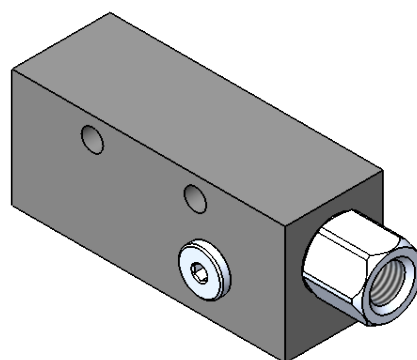

EV20HS-	THREADS	SILENCER
	(Blank) = None	(Blank) = None
	G = G Threads	ST = STA14M

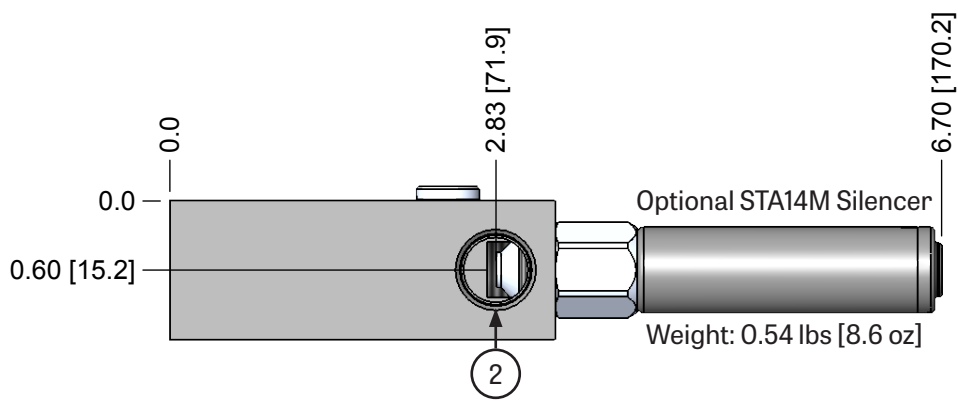
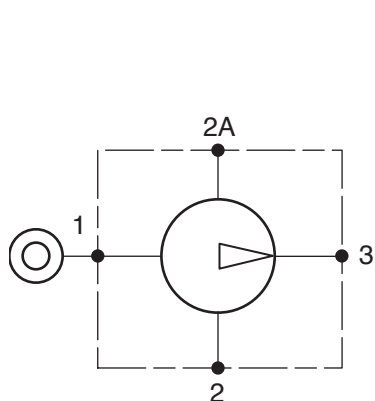
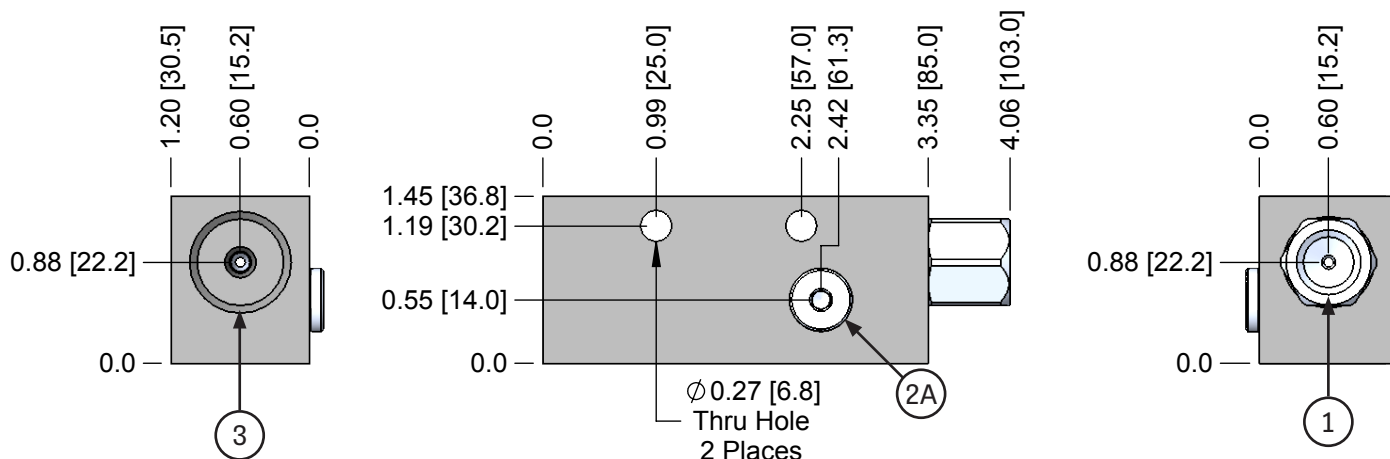

CODE	FUNCTION	NPT	G
1	Air Supply	1/4 NPTF	G 1/4
2	Vacuum	3/8 NPTF	G 3/8
2A	Vacuum - Alternate	G 1/8 NPSF	G 1/8
3	Exhaust	1/4 NPTF	G 1/4

**SINGLE-STAGE PUMPS
EV SERIES PERFORMANCE**

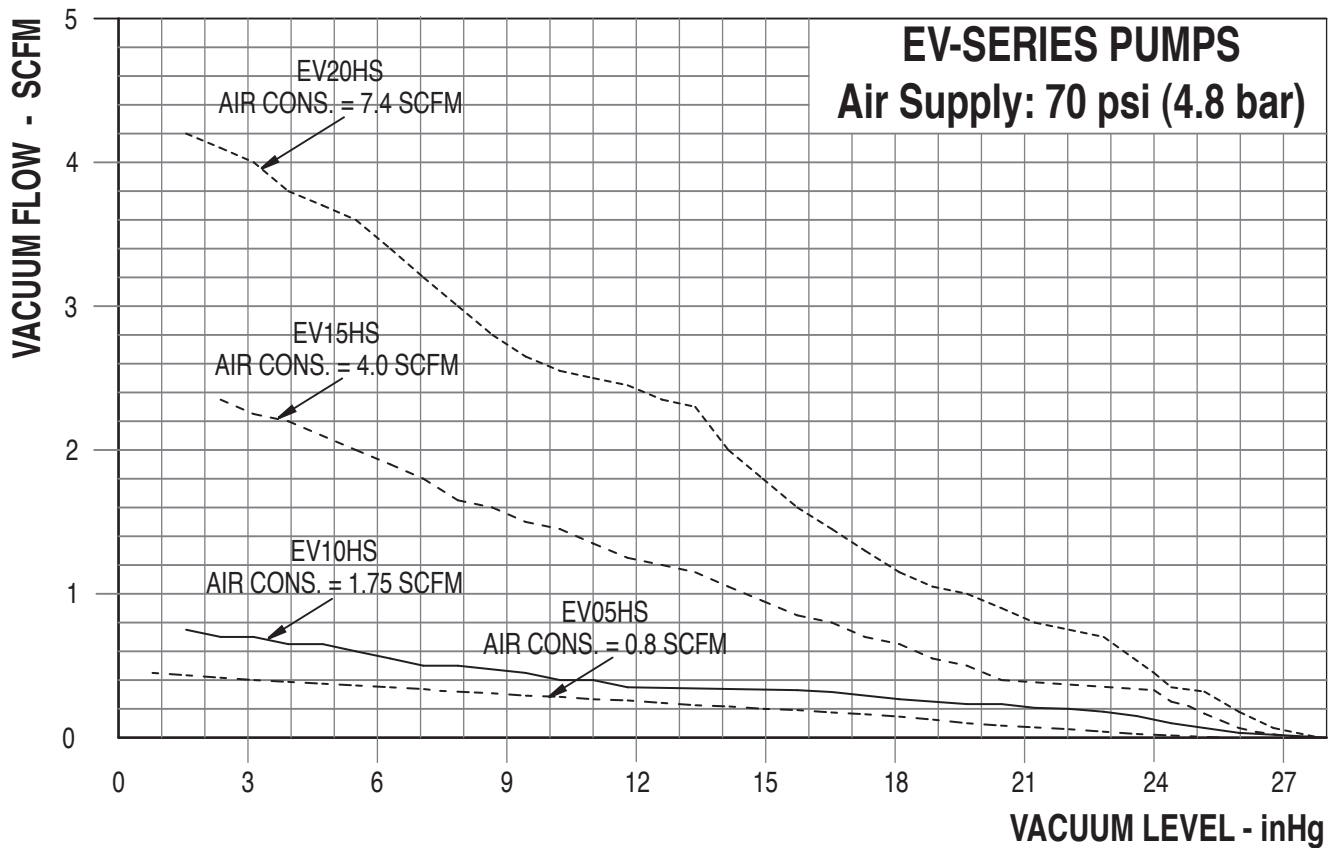

VACUUM FLOW - SCFM

MODEL	AIR SUPPLY PSI	AIR CONS SCFM	MAX VACUUM inHG	SCFM AT VACUUM LEVEL							
				3 inHG	6 inHG	9 inHG	12 inHG	15 inHG	18 inHG	21 inHG	24 inHG
EV05HS	72	0.4	26.7	0.25	0.22	0.20	0.15	0.12	0.7	0.03	0.01
EV10HS	72	1.8	28	0.70	0.57	0.46	0.35	0.33	0.27	0.22	0.13
EV15HS	72	4.0	27.3	2.27	1.94	1.56	1.24	0.94	0.66	0.39	0.33
EV20HS	72	7.4	27.8	4.01	3.48	2.74	2.42	1.78	1.17	0.83	0.45

SCFM X 28.32 = nl / m

EVACUATION TIME - SEC / 100 CU IN

MODEL	AIR SUPPLY PSI	AIR CONS SCFM	MAX VACUUM inHG	SECONDS TO VACUUM LEVEL							
				3 inHG	6 inHG	9 inHG	12 inHG	15 inHG	18 inHG	21 inHG	24 inHG
EV05HS	72	0.4	26.7	1	2.5	4.5	7.5	12.5	20	35	-
EV10HS	72	1.8	28	0.36	0.44	1.6	2.8	4.6	7.6	12.6	23.6
EV15HS	72	4.0	27.3	0.11	0.27	0.5	0.86	1.4	2.3	4.1	7.8
EV20HS	72	7.4	27.8	0.06	0.15	0.3	0.5	0.8	1.3	2.2	4.2

sec / 100 cu in X 0.61 = sec / l

15

All performance data presented is a representation of production pumps but is not a guarantee due to variations in local barometric pressure and of mass produced components.

SINGLE-STAGE PUMPS V SERIES PUMPS

V-Series vacuum pumps are available in 24 models with anodized aluminum bodies plus 12 cartridge models for integration into custom vacuum manifold systems.

EDCO Single-Stage Pumps provide the instantaneous response common to air operated devices in addition to being compact, light, and cost-effective. Rugged, all-metal construction will provide years of trouble-free service.

Our no-clog, flow-through design is perfectly suited for packaging and other applications involving paper fibers or other debris that can be ingested into the vacuum system. Our optional straight-through silencer passes the exhaust directly to atmosphere after absorbing high-frequency noise from the air stream. Many of our competitors use closed-end plastic exhaust mufflers where the exhaust is passed through

a filter media that will accumulate debris, eventually causing a loss of pump performance. In systems where conditions are very dirty, such as woodworking, a vacuum filter should be used to remove dust and debris so they will not be dispersed in the exhaust and breathed by workers.

As always, to obtain maximum benefits of EDCO compressed air powered vacuum pumps, they should be mounted close to the point of vacuum usage to minimize line losses, reduce vacuum system volume, and minimize system evacuation time.

For ease of mounting, V-Series Pump bodies feature square or rectangular cross-sections and include mounting holes. This results in a much simpler installation with a better appearance than with cylindrical body vacuum pumps.

PRINCIPLE OF OPERATION

To generate vacuum, compressed air is supplied to the inlet of a shaped primary nozzle to concentrate the air stream so that it increases in velocity as it passes through the nozzle throat. As velocity increases, pressure decreases until it is below atmospheric pressure (vacuum) and the high-velocity air stream is passed into a second nozzle that is spaced away from the end of the primary nozzle. The gap between the two nozzles occurs within a chamber with a threaded port for connecting to a system requiring a vacuum source. As evacuated air flows into the vacuum port, it is drawn into a second nozzle where it is mixed with air from the primary nozzle and combined flow is exhausted to atmosphere after passing through a silencer where expansion continues and noise is absorbed by an acoustic media.

To stop the vacuum, the compressed air supply is removed and vented by a 3-way supply valve. When air flow stops, vacuum is no longer generated and ambient air flows into the exhaust and into the vacuum line to dissipate the residual vacuum thereby releasing work pieces from vacuum cups or other vacuum holders in the system.

Geometry of the primary and secondary nozzles determines the shape of the pump performance curve and the depth of vacuum that can be achieved. Nozzles are optimized for operation at specific pressure but can be used at other supply pressures to suit an application. When operating at some non-optimum air pressure, a rapid popping noise may be heard in the exhaust which is caused when air velocity achieves unstable, supersonic / subsonic velocity and can be eliminated by slightly increasing or decreasing the air supply pressure.

There are many terms for these devices included generator, ejector, and venturi. They are commonly called vacuum pumps in the industry, so that is the term we use. No matter what the name is, they are very useful for providing fast, reliable, compact, low-cost vacuum sources for all manners of application.

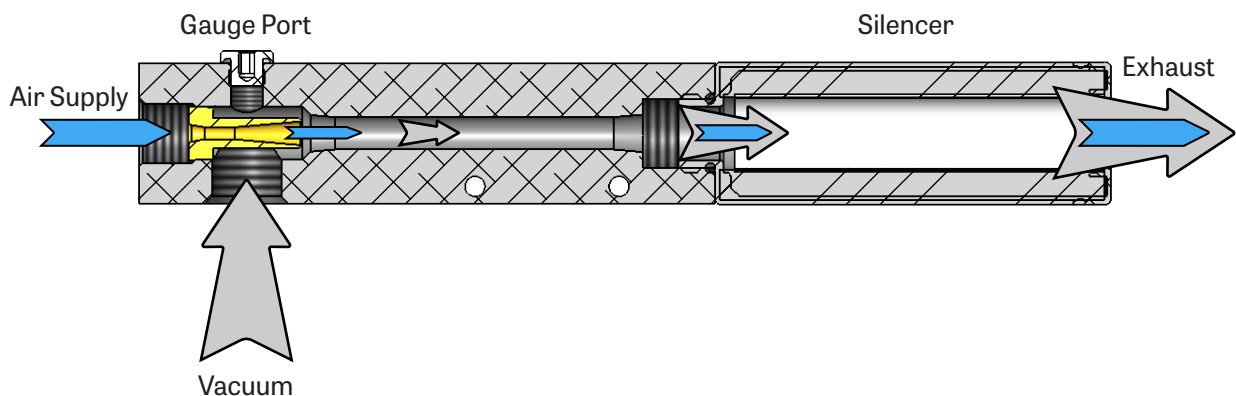

SINGLE-STAGE PUMPS V SERIES PUMPS

VENTURI CARTRIDGE

V10 and V20 Series Nozzle Sets can be ordered on their own for use in your custom applications.

Contact EDCO USA for cavity detail drawing.

	NOZZLE SET	SERIES
V-	60	H
	60	H
	90	H-60
	100	M
	150	M-60

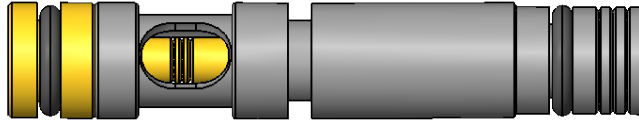

V10 BODY

BLOW-OFF OPTIONS
(Blank) = None
X = Blow-Off
XA = Adjustable Blow-Off

NOZZLE SET	SERIES
60	H
60	H
90	H-60
100	M
150	M-60

PORTS
(Blank) = NPT
G = G Threads

SILENCER
(Blank) = None
ST - STA14M

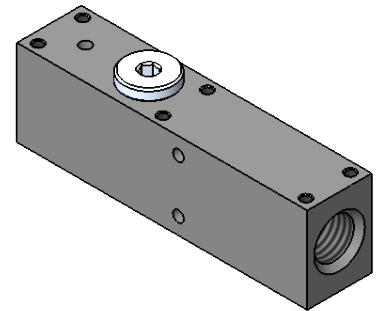

Weight: 0.33 lbs [149.0 g]

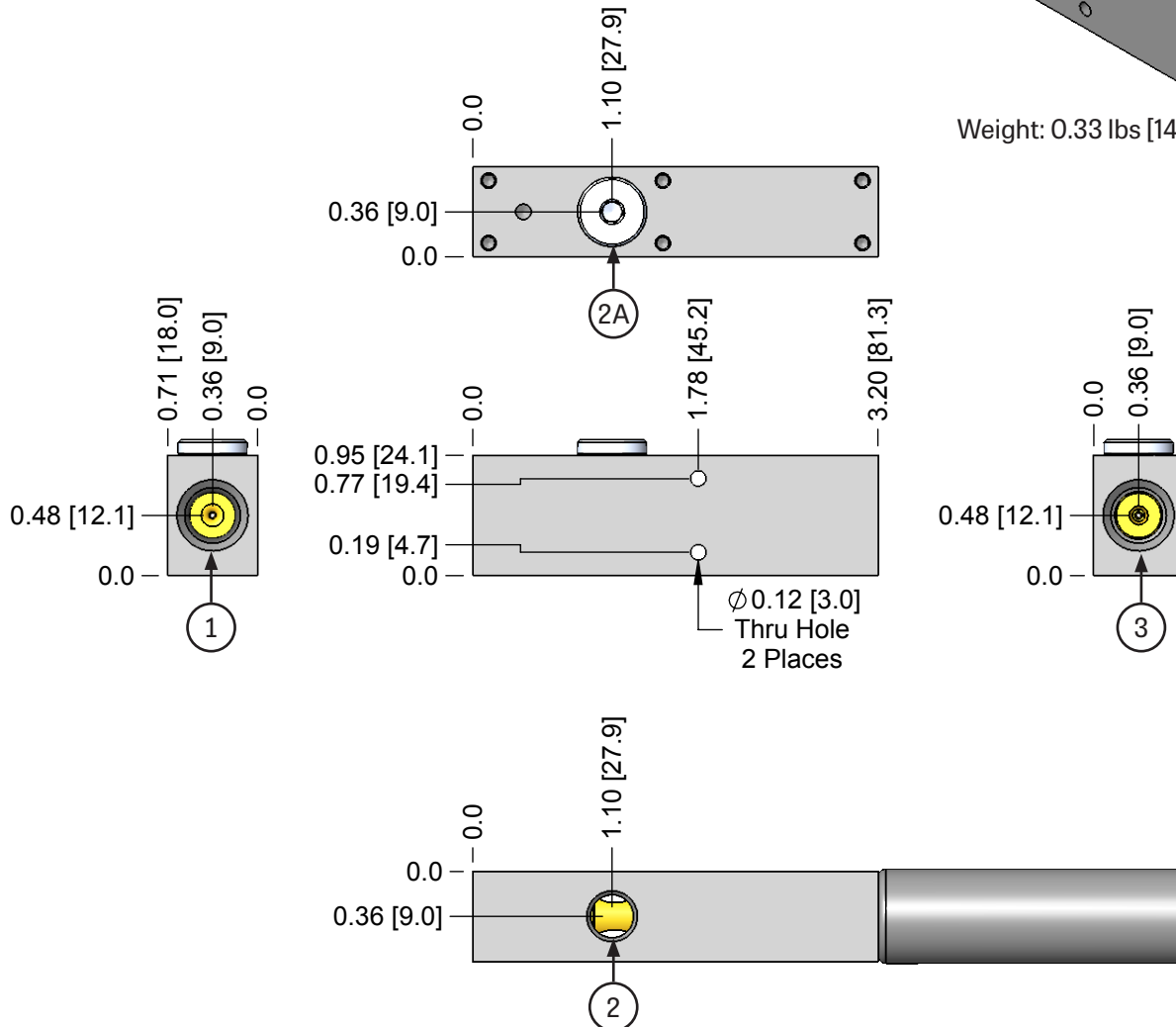

CODE	FUNCTION	NPT	G
1	Air Supply	1/4 NPTF	G 1/4
2	Vacuum	G 1/8 NPSF	G 1/8 NPSF
2A	Vacuum - Alternate	G 1/8 NPSF	G 1/8 NPSF
3	Exhaust	1/4 NPTF	G 1/4

SINGLE-STAGE PUMPS V SERIES PUMPS

V20 BODY

V20	BLOW-OFF OPTIONS	NOZZLE SET	SERIES	PORTS	SILENCER
	(Blank) = None	90	H	(Blank) = NPT	(Blank) = None
	X = Blow-Off	60	H	G = G Threads	ST - STA14M
	XA = Adjustable Blow-Off	90	H-60		
		100	M		
		150	M-60		

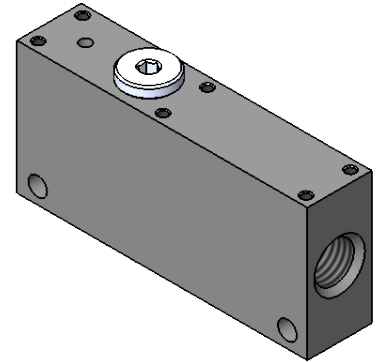

Weight: 0.43 lbs [195.0 g]

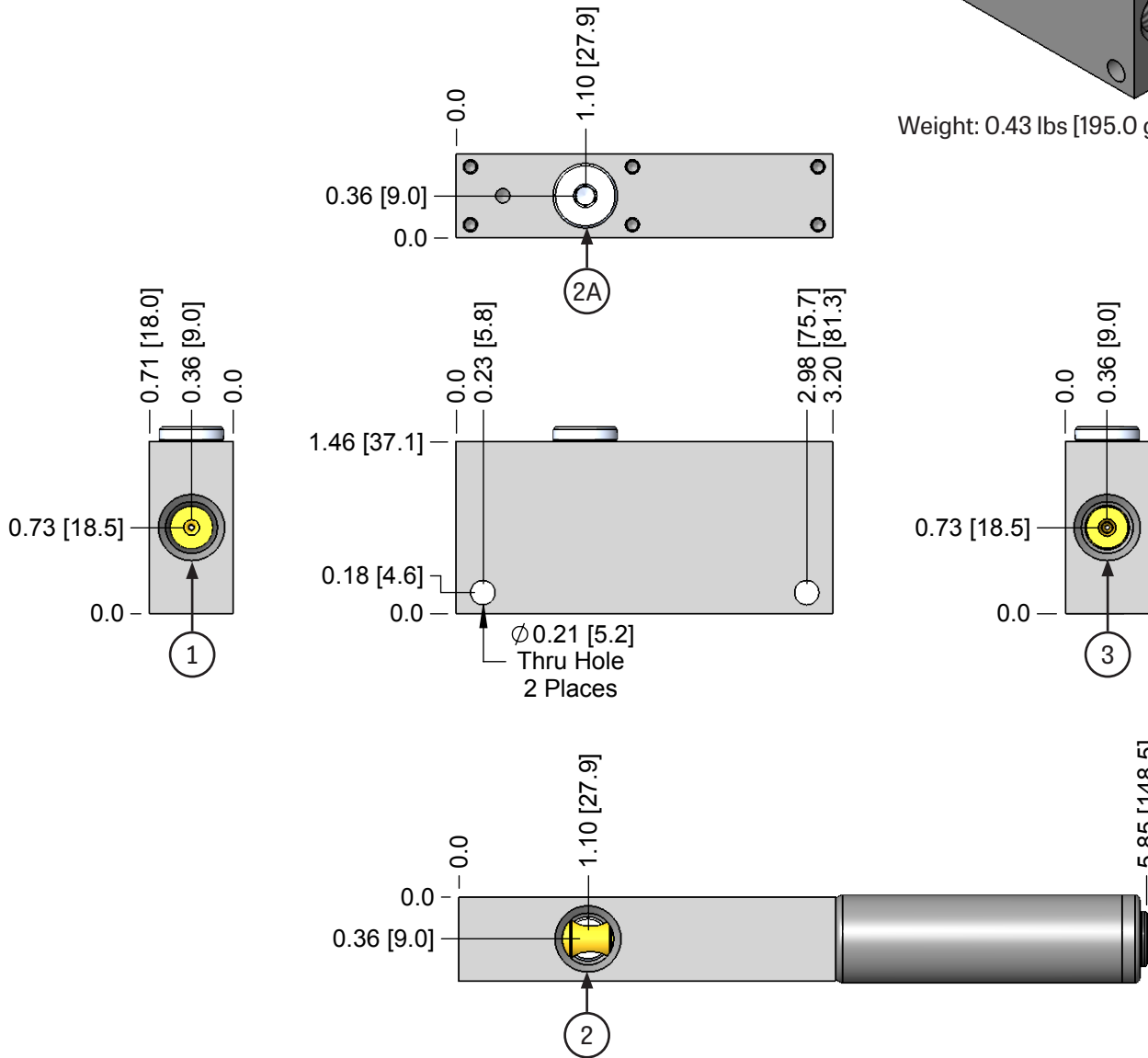

CODE	FUNCTION	NPT	G
1	Air Supply	1/4 NPTF	G 1/4
2	Vacuum	1/4 NPTF	G 1/4
2A	Vacuum - Alternate	G 1/8 NPSF	G 1/8 NPSF
3	Exhaust	1/4 NPTF	G 1/4

SINGLE-STAGE PUMPS V SERIES PUMPS

V80 BODY

BLOW-OFF OPTIONS	NOZZLE SET	SERIES	PORTS	SILENCER
(Blank) = None	200	H	(Blank) = NPT	(Blank) = None
X = Blow-Off	200	H	G = G Threads	ST
XA = Adjustable Blow-off	250	H-60		
		M		
		M-60		

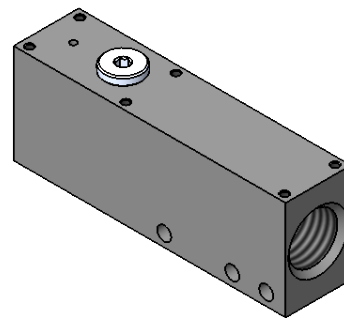

200 Weight: 0.53 lbs [240.0 g]
250 Weight: 0.51 lbs [231.0 g]

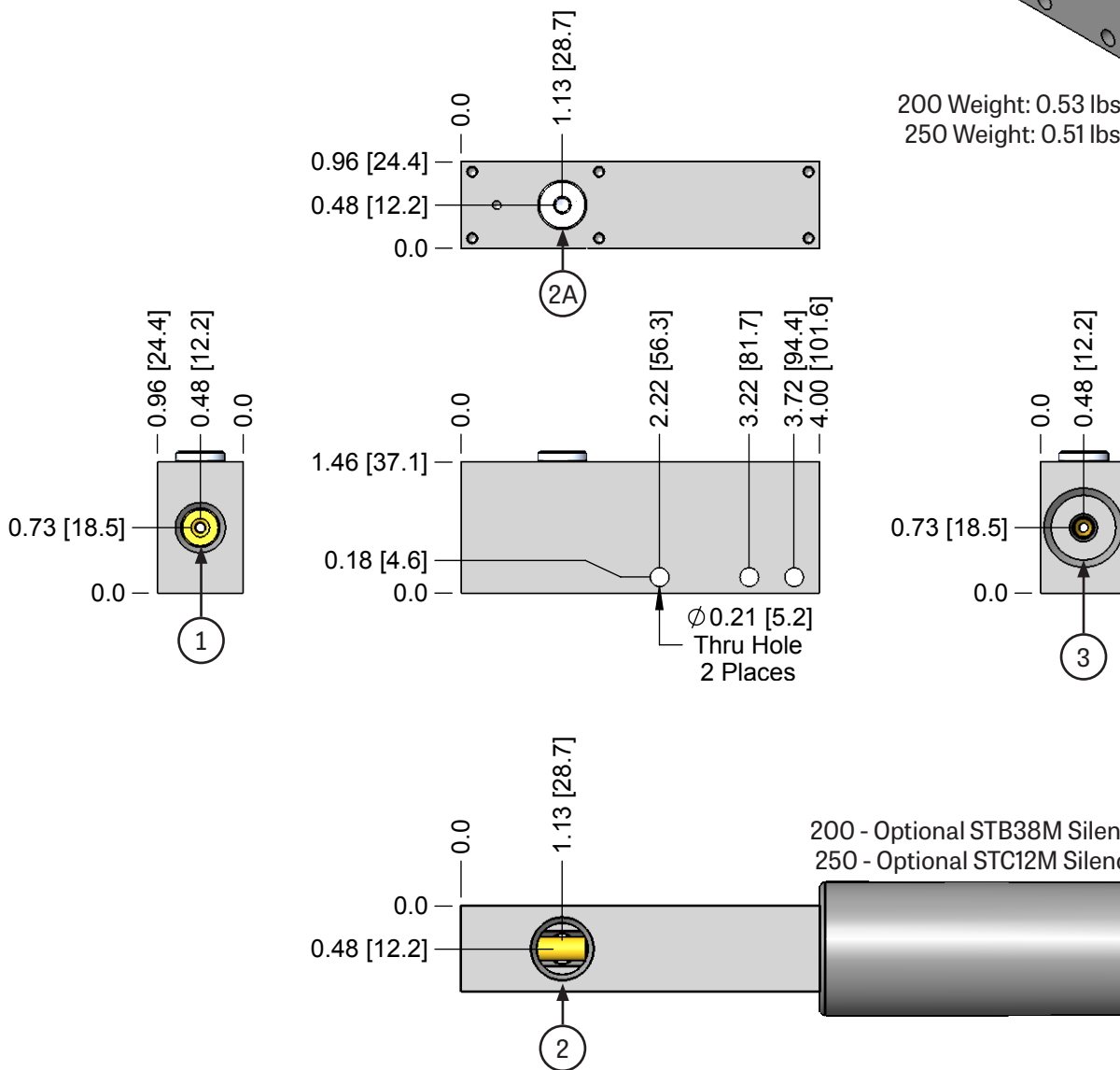

15

CODE	FUNCTION	200 - NPT	200 - G	250 - NPT	250 - G
1	Air Supply	1/4 NPTF	G 1/4	1/4 NPTF	G 1/4
2	Vacuum	3/8 NPTF	G 3/8	3/8 NPTF	G 3/8
2A	Vacuum - Alternate	G 1/8 NPSF	G 1/8 NPSF	G 1/8 NPSF	G 1/8 NPSF
3	Exhaust	3/8 NPTF	G 3/8	1/2 NPTF	G 1/2

SINGLE-STAGE PUMPS V SERIES PUMPS

V90 BODY

NOZZLE SET	SERIES	PORTS	SILENCER
300	H		
300	H	(Blank) = NPT	(Blank) = None
350	H-60	G = G Threads	ST
	M		
	M-60		

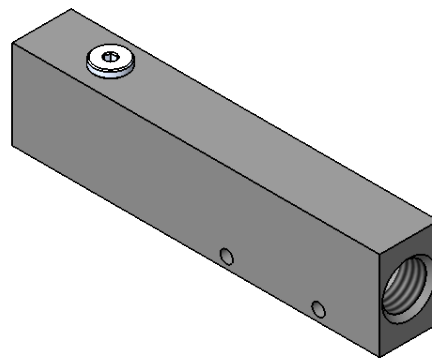

Weight: 0.73 lbs [331.0 g]

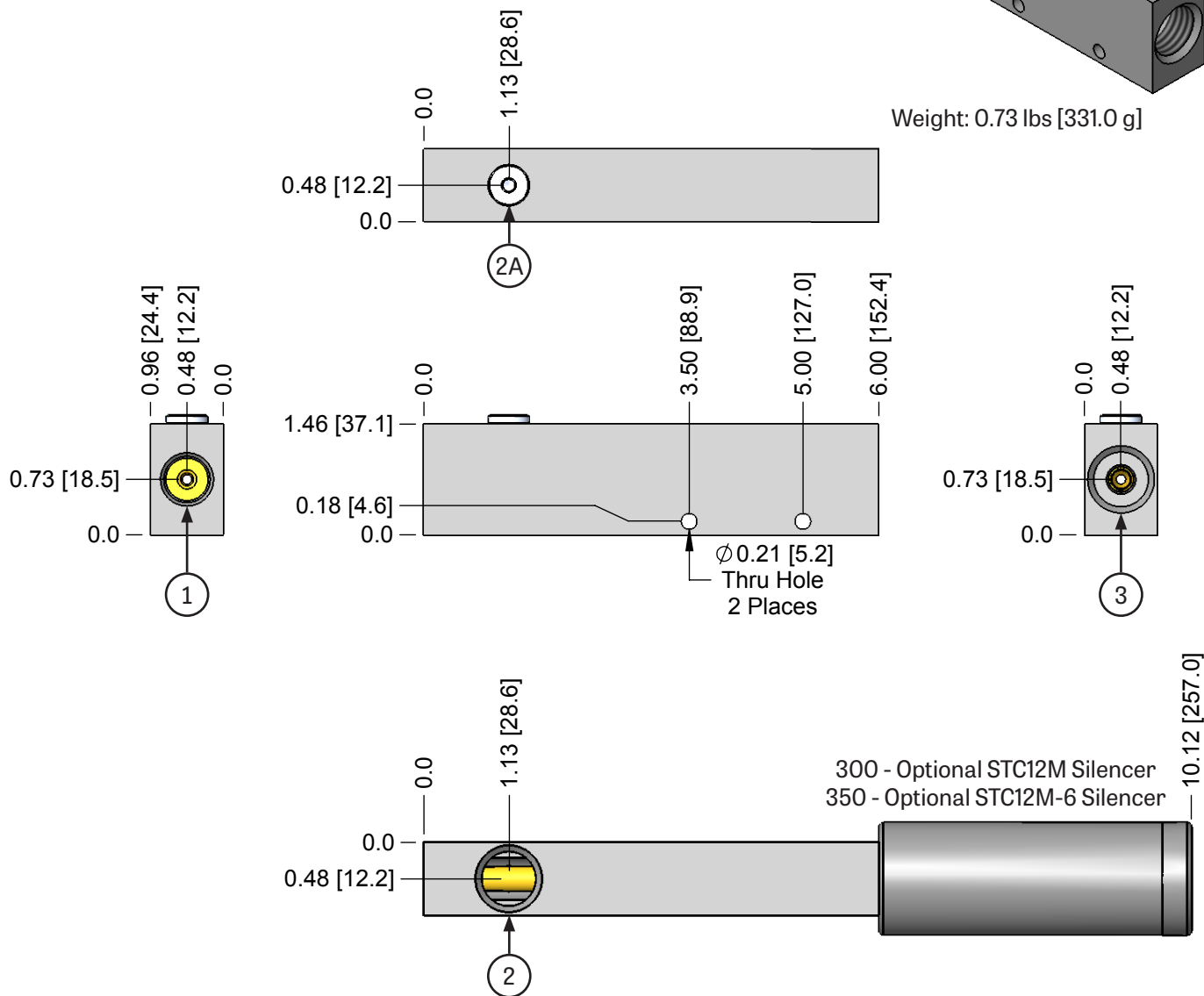

CODE	FUNCTION	NPT	G
1	Air Supply	3/8 NPTF	G 3/8
2	Vacuum	1/2 NPTF	G 1/2
2A	Vacuum - Alternate	G 1/8 NPSF	G 1/8 NPSF
3	Exhaust	1/2 NPTF	G 1/2

SINGLE-STAGE PUMPS VX - V PUMPS W/ AUTOMATIC BLOW-OFF

Same performance as a standard V-series but with automatic quick-release blow-off module. Air supply to the pump fills a volume chamber via an integral quick exhaust valve. When the pump air supply is turned off and pressure drops about

5 psi (0,3 bar), the quick exhaust valve shifts and passes the stored volume directly into the pump vacuum port to quickly dissipate system vacuum for a faster cycle time.

V10X

Storage Volume: 1.0 in³ (16.4 ml)

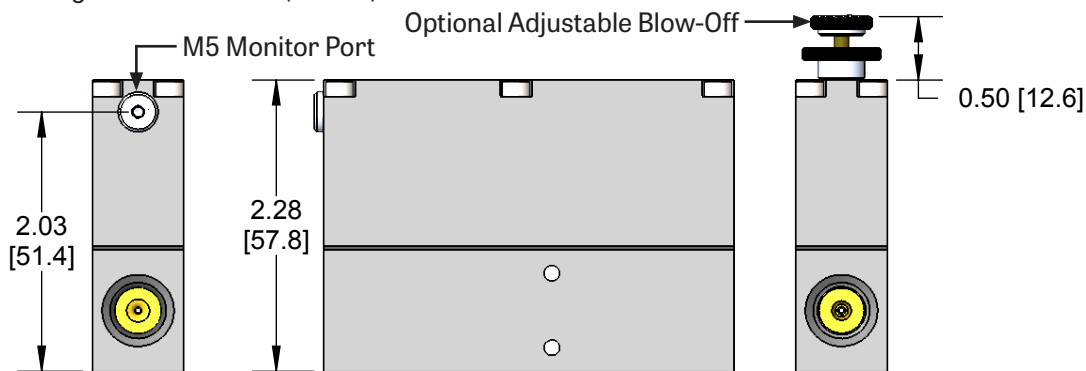

Weight: 0.33 lbs [149.0 g]

V20X

Storage Volume: 1.0 in³ (16.4 ml)

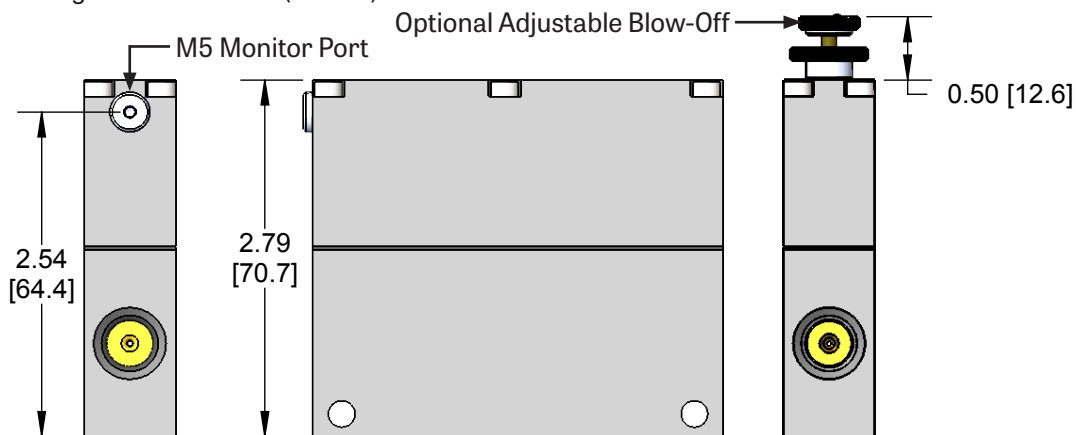

Weight: 0.43 lbs [195.0 g]

V80X

Storage Volume: 2.8 in³ (45 ml)

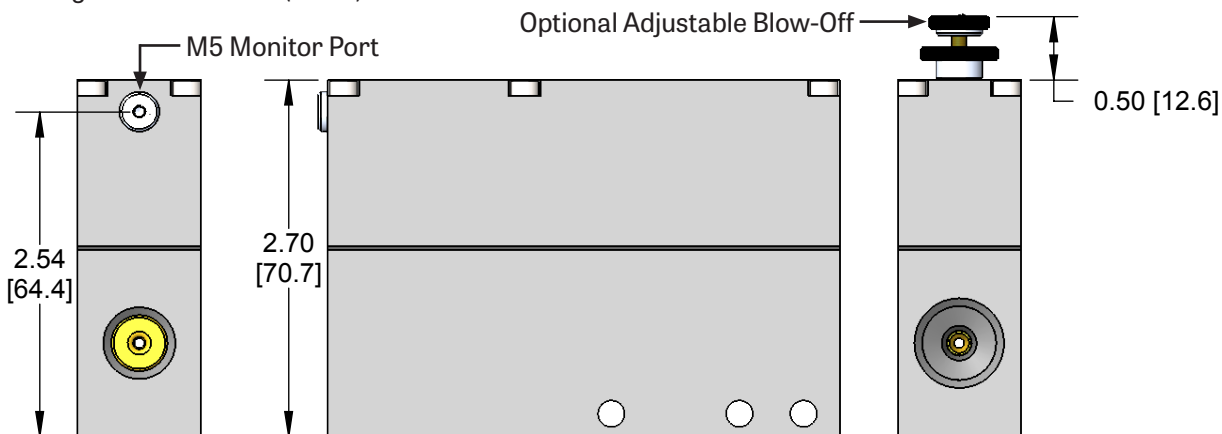

Weight: 0.71 lbs [322.0 g]

SINGLE-STAGE PUMPS PERFORMANCE

SERIES	DESCRIPTION	MAX VACUUM
M	High Flow	20 inHG
H	High Vacuum	28 inHG

VACUUM FLOW - SCFM

MODEL	AIR CONS SCFM @ 80 PSI	MAX VACUUM inHG	SCFM AT VACUUM LEVEL								
			3 inHG	6 inHG	9 inHG	12 inHG	15 inHG	18 inHG	21 inHG	24 inHG	27 inHG
90H	1.7	26.7	0.7	0.6	0.4	0.35	0.3	0.21	0.17	0.06	0
100H	2.5	27.5	1.4	1.2	1	0.7	0.55	0.36	0.28	0.21	0.02
150H	4.7	26.7	2.1	1.8	1.4	1.2	0.9	0.66	0.37	0.22	0
200H	7.9	26.7	4.3	3.5	2.8	2.1	1.3	0.72	0.43	0.15	0
250H	13.4	27.5	7.1	6.1	5.1	4	2.9	2.1	1.4	0.35	0.12
300H	20.0	27.5	12.9	11.3	9.2	7.3	5.6	4.1	2.6	0.7	0.1
350H	27.0	27.5	14	12	10.2	7.7	5.9	4.2	3	1.2	0.14
90M	1.8	20.2	0.73	0.52	0.45	0.42	0.33	0.12	0	-	-
100M	1.9	21.6	1.8	1.5	1.3	1	0.6	0.34	0.08	-	-
150M	2.9	20.8	2.7	2.3	1.8	1.1	0.6	0.34	0	-	-
200M	5.2	20	5.1	4.3	3.4	2.4	1.2	0.46	0	-	-
250M	8.6	19.2	8.9	7.2	5.3	3.2	1.2	0.24	0	-	-
300M	13.3	19.6	14.4	12	9.8	7.4	5.3	2.4	0	-	-
350M	20.4	22.4	18.4	15.9	13.5	11.2	7.9	4.6	1.7	-	-

SCFM X 28.32 = nl / m

EVACUATION TIME - SEC / 100 IN³

MODEL	AIR CONS SCFM @ 80 PSI	MAX VACUUM inHG	SECONDS TO VACUUM LEVEL								
			3 inHG	6 inHG	9 inHG	12 inHG	15 inHG	18 inHG	21 inHG	24 inHG	27 inHG
90H	1.7	26.7	3.5	13	17	29	48	79	135	255	-
100H	2.5	27.5	1.9	4.5	8.3	14	24	39	68	129	325
150H	4.7	26.7	1.2	2.9	5.4	9.3	15	25	43	82	-
200H	7.9	26.7	0.64	1.5	2.9	4.6	8.1	13	24	46	-
250H	13.4	27.5	0.36	0.87	1.6	2.7	4.5	7.3	13	24	62
300H	20.0	27.5	0.2	0.48	0.87	1.5	2.4	4	6.9	13	34
350H	27.0	27.5	0.18	0.44	0.81	1.2	2.3	3.7	6.4	12	31
90M	1.8	20.2	3.4	12	17	28	46	76	-	-	-
100M	1.9	21.6	1.7	3.5	6.4	11	18	31	54	-	-
150M	2.9	20.8	0.93	2.3	4.2	7.3	13	22	-	-	-
200M	5.2	20	0.48	1.2	2.2	3.8	6.4	12	-	-	-
250M	8.6	19.2	0.29	0.69	1.3	2.3	4.1	7.2	-	-	-
300M	13.3	19.6	0.18	0.43	0.81	1.4	2.3	3.8	-	-	-
350M	20.4	22.4	0.14	0.34	0.64	1	1.7	2.8	4.9	-	-

sec/100 in³ X 0.61 = sec / l

All performance data presented is a representation of production pumps but is not a guarantee due to variations in local barometric pressure and of mass produced components.

**SINGLE-STAGE PUMPS
V SERIES PERFORMANCE**

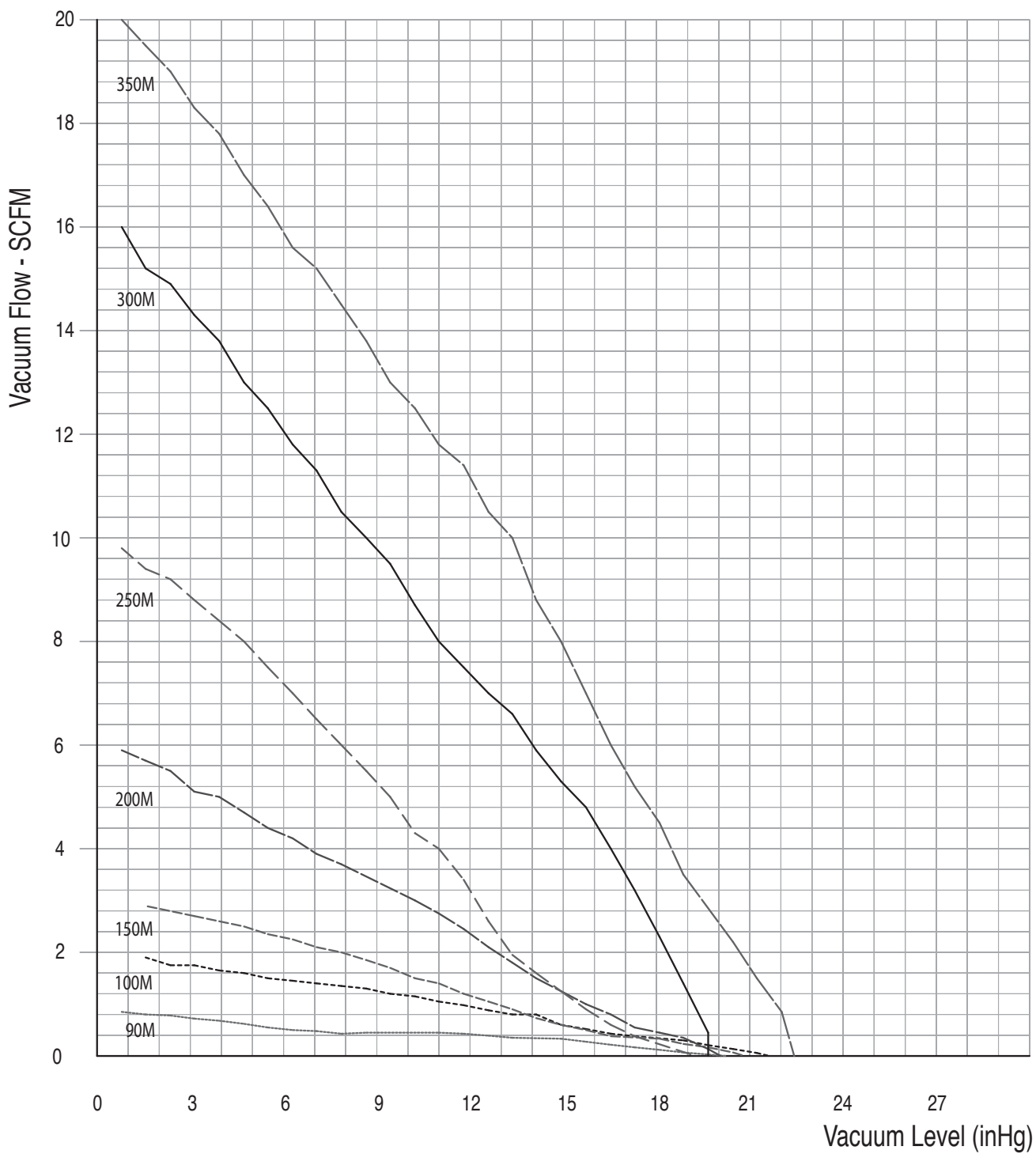

15

All performance data presented is a representation of production pumps but is not a guarantee due to variations in local barometric pressure and of mass produced components.

**SINGLE-STAGE PUMPS
V SERIES PERFORMANCE**

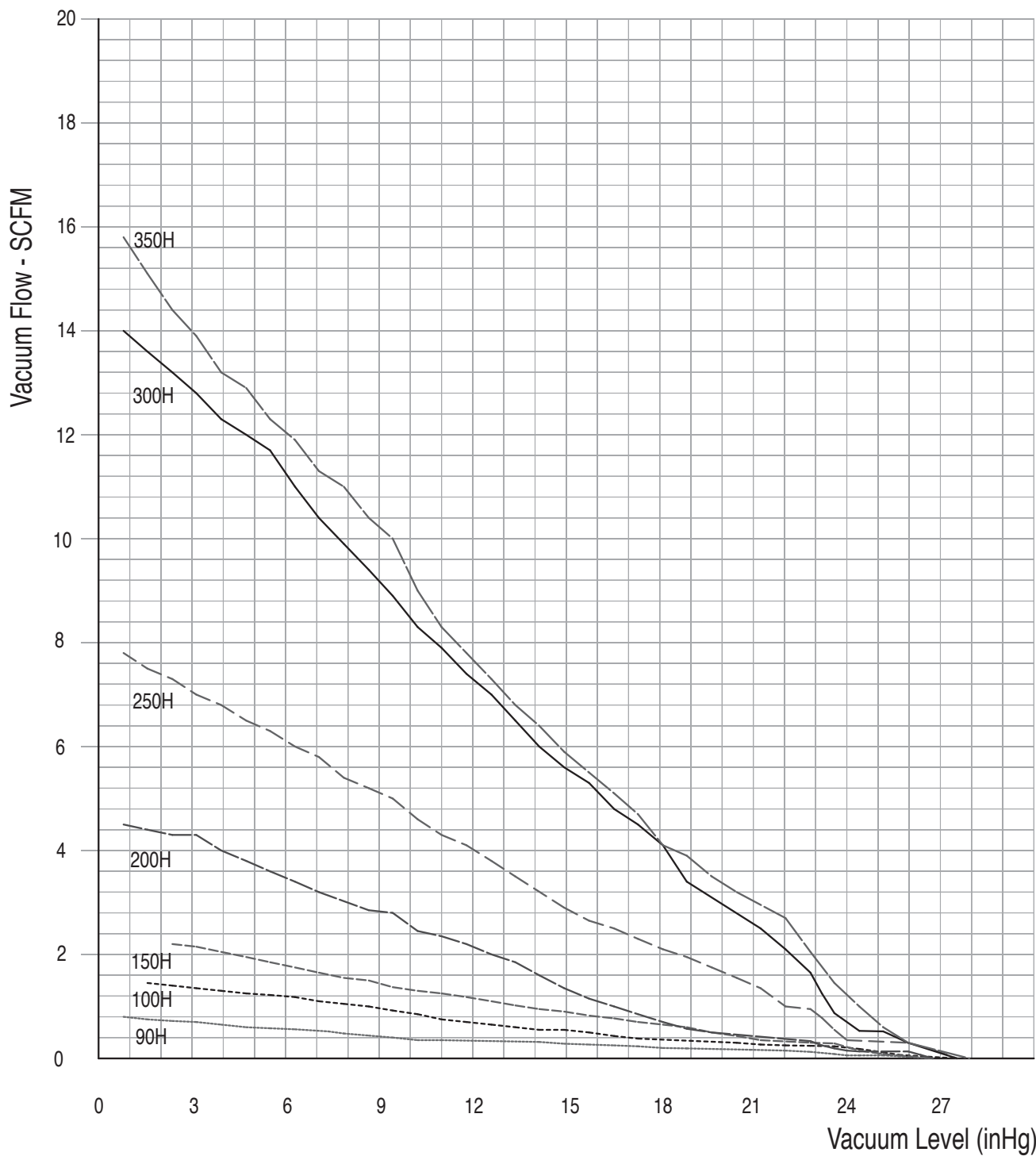

All performance data presented is a representation of production pumps but is not a guarantee due to variations in local barometric pressure and of mass produced components.

SINGLE-STAGE PUMPS

SM24-38 COMPACT PUMP

The SM24-38 is a multi-characteristic pump with three operating pressures. It is compact, light-weight, economical, maintenance free, energy efficient, and quiet. Made of brass nozzles and an anodized aluminum body, the SM24-38 has a high flow rate with a maximum air supply of 100 psi. With its metal construction and stainless steel fasteners, the SM24-38 is also a very rugged pump.

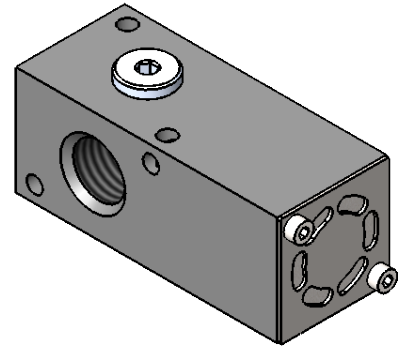

Weight: 0.35 lbs [5.6 oz]

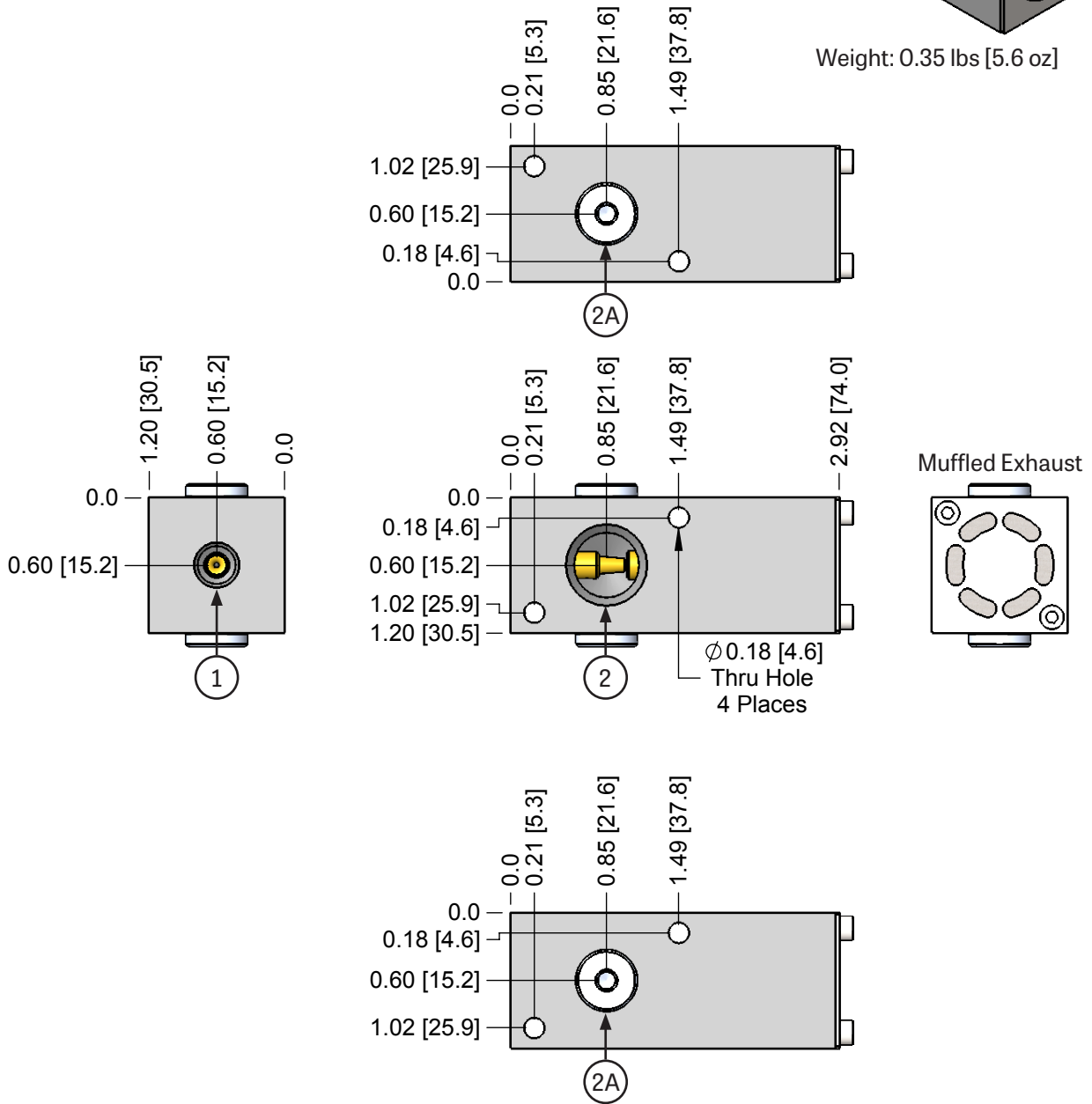

CODE	FUNCTION	SIZE
1	Air Supply	G 1/8 NPS
2	Vacuum - Main	3/8 NPS
2A	Vacuum - Alternate	G 1/8 NPS

SINGLE-STAGE PUMPS SM24-38 COMPACT PUMP

Mini-System pumps are equipped with 3 vacuum ports so separate manifolds can be eliminated from the system.

“Pump-to-Point” plumbing reduces vacuum losses by eliminating extra system fittings.

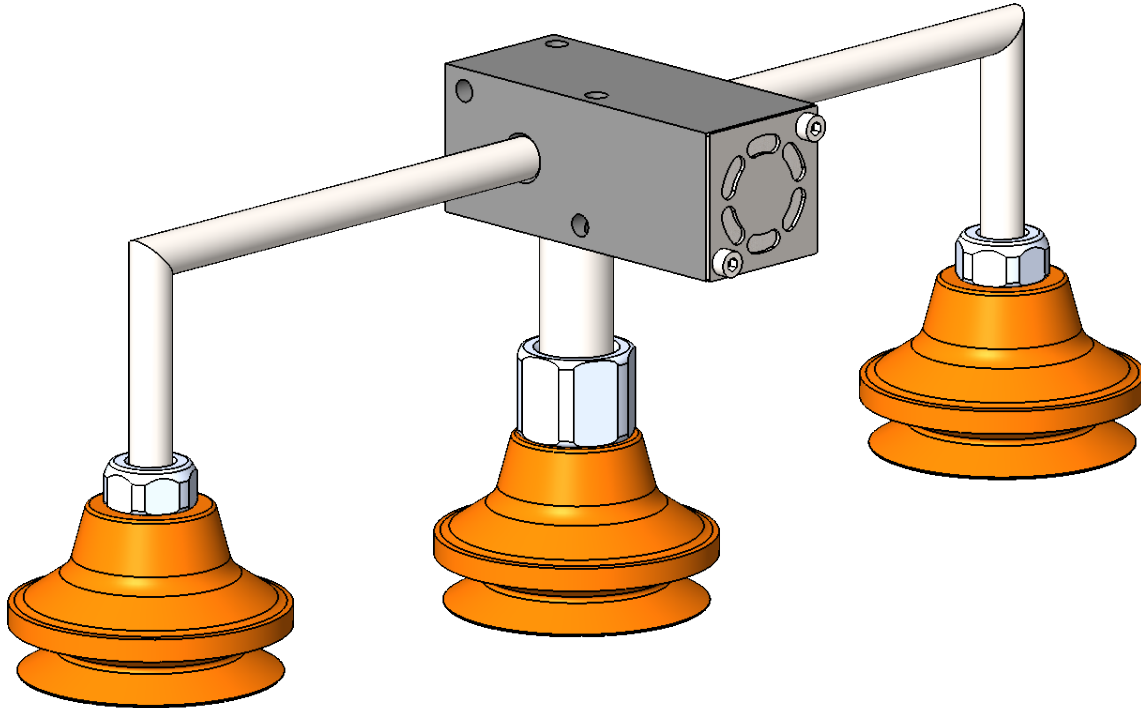

VACUUM FLOW VS VACUUM LEVEL

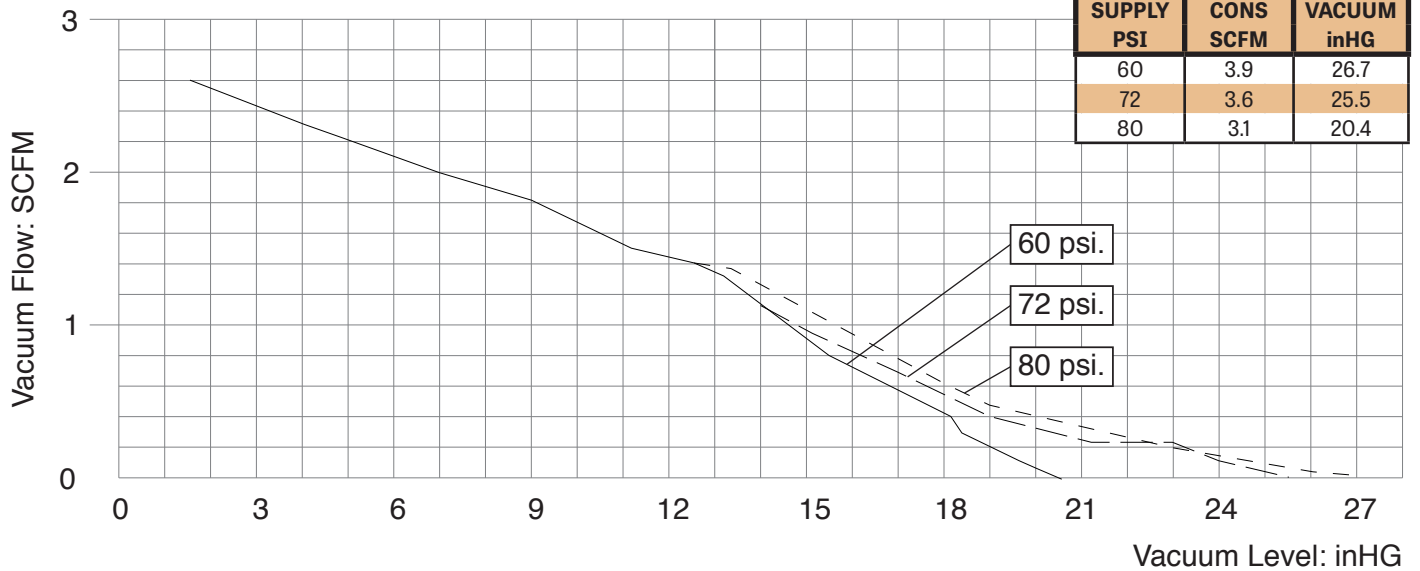

All performance data presented is a representation of production pumps but is not a guarantee due to variations in local barometric pressure and of mass produced components.

SINGLE-STAGE PUMPS VARIABLE DISPLACEMENT PUMPS

VDS vacuum pumps can provide over 20" Hg (68 kPa) and their straight through non-clog design is ideal for very dusty and dirty applications such as bag filling or handling ceramics or masonry products. The square body and two mounting holes makes the VDS pump easy to attach to any flat surface. An ST Straight Thru silencer will not accumulate debris and will pass it out with the exhaust air. For less critical applications where cost is more of an issue, a conventional AA silencer may be used.

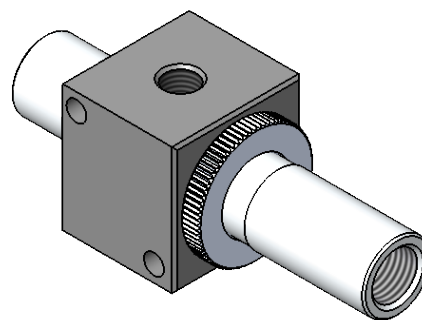

MODEL	PORTS	SILENCER
VDS-150	(Blank) = NPT	(Blank) = None
VDS-150	G = G Threads	ST
VDS-200		
VDS-250		
VDS-375		

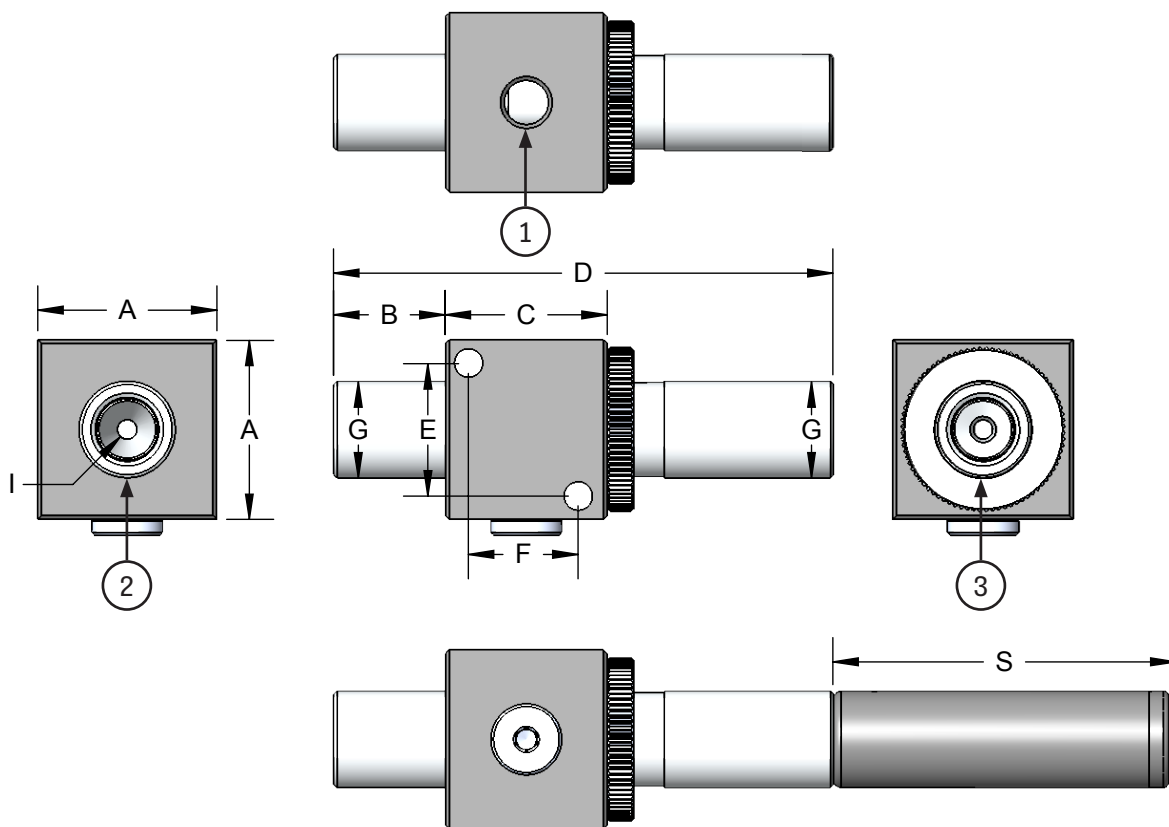

MODEL	1 - AIR SUPPLY	2 - VACUUM	3 - EXHAUST	A	B	C	D	E	F	G	H	I	S
VDS-150	G 1/8 NPSF	1/4 G 1/4	1/4 G 1/4	1.38 [35.0]	0.86 [21.8]	1.25 [31.8]	3.81 [96.7]	1.02 [25.9]	0.84 [21.3]	0.74 [18.8]	0.22 [5.5]	0.15 [3.8]	2.65 [67.3]
VDS-200	G 1/8 NPSF	1/4 G 1/4	1/4 G 1/4	1.38 [35.0]	0.86 [21.8]	1.25 [31.8]	3.81 [96.7]	1.02 [25.9]	0.84 [21.3]	0.74 [18.8]	0.22 [5.5]	0.2 [5.1]	2.65 [67.3]
VDS-250	G 1/8 NPSF	1/4 G 1/4	1/4 G 1/4	1.38 [35.0]	0.86 [21.8]	1.25 [31.8]	3.81 [96.7]	1.02 [25.9]	0.84 [21.3]	0.74 [18.8]	0.22 [5.5]	0.25 [6.3]	2.65 [67.3]
VDS-375	3/8 NPSF	G 1/2 NPSF	G 1/2 NPSF	1.72 [43.7]	1.5 [38.1]	1.75 [44.5]	5.99 [152.0]	1.32 [33.5]	1.35 [34.3]	0.98 [24.9]	0.26 [6.6]	0.38 [9.5]	4.12 [104.6]

MODEL	MAX VAC FLOW SCFM	AIR CONSUMPTION vs VACUUM LEVEL @ 80 PSI						SILENCER
		0 inHG	5 inHG	10 inHG	15 inHG	20 inHG	25 inHG	
VDS-150	3.2	0	1.3	1.7	2.4	3.2	4.5	STA14M
VDS-200	6	0	2.4	3.7	4.7	6	6.8	STA14M
VDS-250	10	0	4	6	8.3	9.7	12	STA14M
VDS-375	30	0	6.2	11.5	17	21	29	STC12M

All performance data presented is a representation of production pumps but is not a guarantee due to variations in local barometric pressure and of mass produced components.

SINGLE-STAGE PUMPS VARIABLE DISPLACEMENT PUMPS

OPERATION

Loosen the jam nut and turn the diffuser nozzle clockwise, by hand, until it contacts the inlet nozzle. With the work piece against the suction cup or holding fixture, supply regulated compressed air to the side air supply port and gradually rotate the diffuser nozzle to adjust the annular gap between the two nozzles until the desired vacuum level or vacuum flow is achieved. To minimize air consumption, use the lowest pressure air supply that will yield the desired results. Turning the diffuser too far open will suddenly cause a decrease in performance and this point will vary depending on the operating air pressure.

Ingested debris passes directly from end-to-end through the pump bore without any turns and without passing through the annular venturi created by the inlet and diffuser nozzles, so there is no opportunity for clogging as long as the pump bore is large enough to pass the largest debris particle. As the pump bore size is increased, it can also generate more vacuum flow to overcome porosity and leakage.

